

Sentinel A1 – Assembly instructions for use

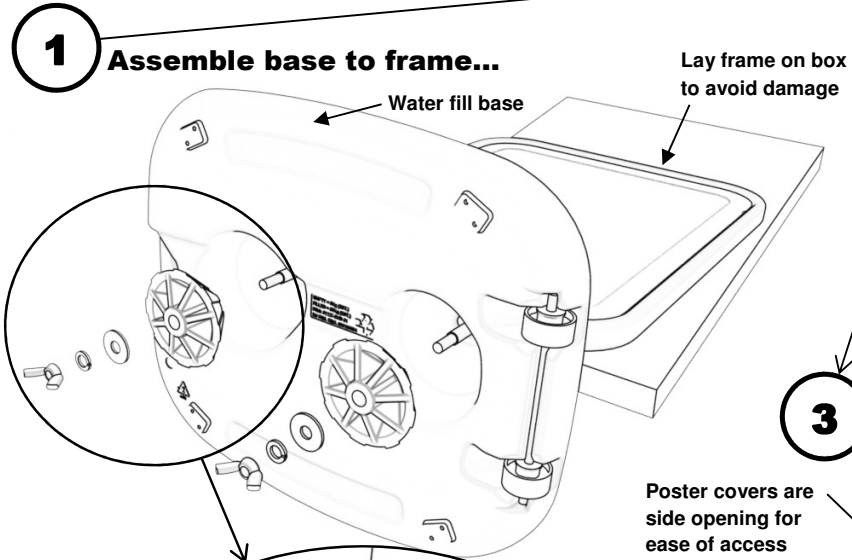

Fill base using a hose (supplied separately) until overflowing. Reinstall bung once full.



IMPORTANT!
SIGN IS AT RISK OF FALLING OVER IF BASE IS NOT FULLY FILLED WITH WATER. RESPONSIBILITY RESTS WITH THE USER.

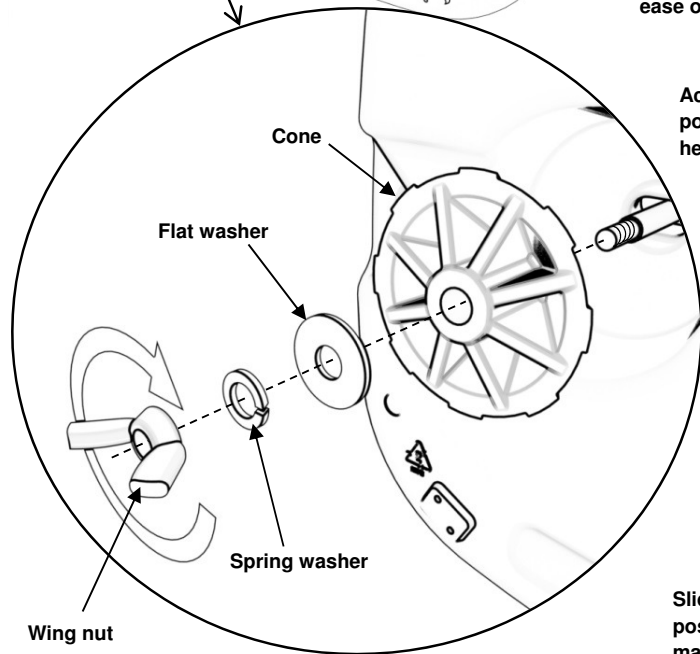

Slide A1 poster into position (fit within magnetic tape border to minimise water ingress)



S-0270-01 (CRN2018-155)